

### Product Features

- 0.01 MHz to 12GHz
- +12 dBm P-1dB at 2GHz
- +27 dBm OIP3 at 2GHz
- 12 dB Gain at 2GHz
- 5.5 dB Noise Figure
- Internally-Matched to 50 Ω
- Available as bare die

### Product Description

The GSA612-00 is a 50 Ohm matched General Purpose Gain Block Amplifier that covers the 0.01MHz to 12GHz frequency range with 12dB nominal gain at 2GHz.

The GSA612-00 is a Darlington pair amplifier fabricated with high reliability InGaP/GaAs Heterojunction Bipolar Transistor (HBT) process. It only requires DC blocking capacitors, a bias stabilization resistor, R<sub>bias</sub>, and a single RF choke for operation. The amplifier is ideal for wireless and test equipment applications.

This broadband RFIC can be used for current and next generation test equipment and wireless applications to 14GHz

### Applications

- Mobile infrastructure
- ISM
- WLAN
- RFID
- Test Equipment

### Specifications (1)

Parameter	Units	Min	Typ	Max
-3dB Bandwidth	MHz	DC		17000
Test Frequency	MHz		2000	
Gain	dB	11.5	12	
Pout @ -1dB GCP	dBm		+12	
Input Return Loss	dB		15	
Output Return Loss	dB		15	
OIP3	dBm		27	
Noise Figure	dB		5.5	
Operating Current	mA		48	

1. Test conditions unless otherwise specified: 25°C, Supply Voltage = +6.00V, R<sub>bias</sub>=22Ω, 50 Ohm System

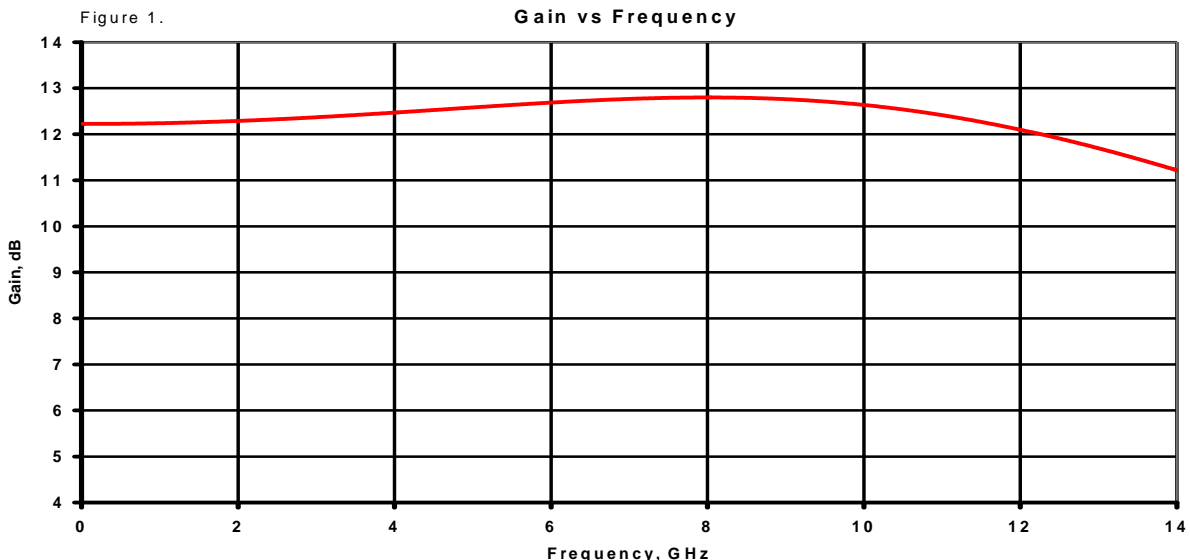

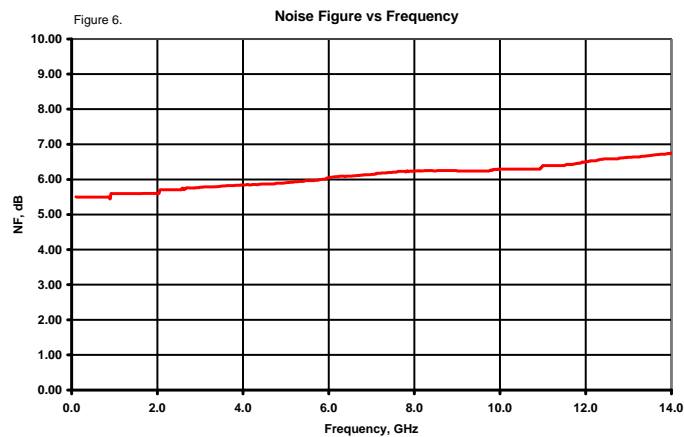
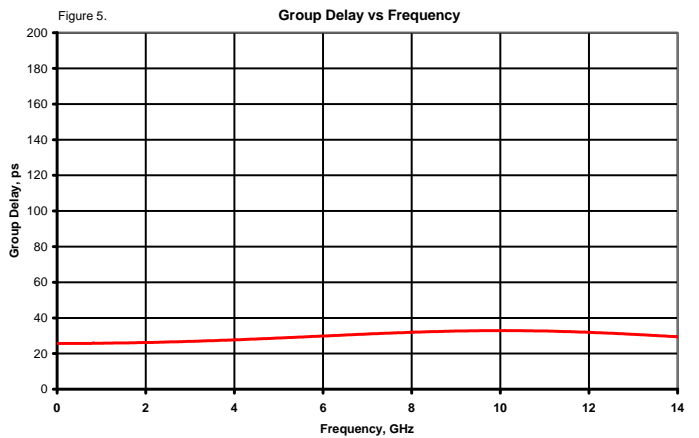
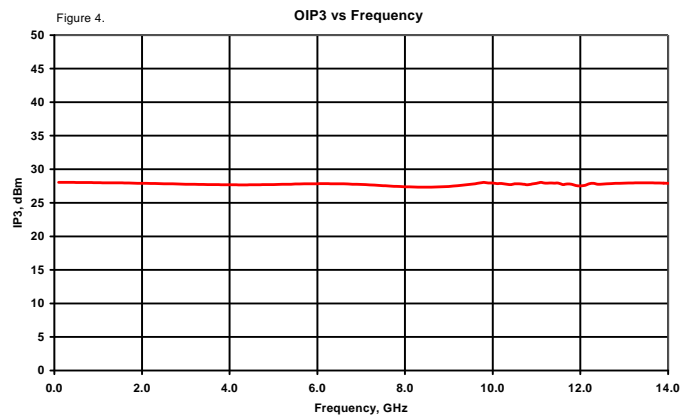
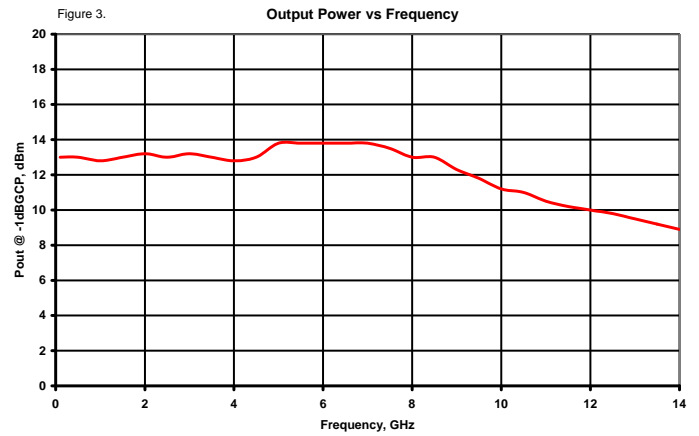
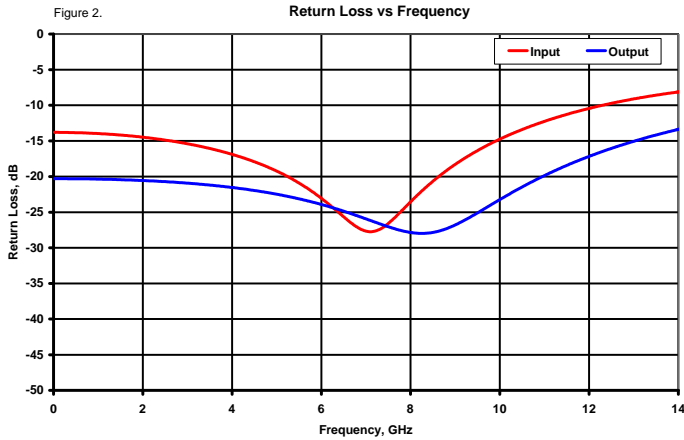

### Absolute Maximum Ratings

Parameter	Rating
Case Temperature, Operating	-40 to +85 °C
Storage Temperature	-55 to +150 °C
Device Current	80mA
RF Input Power, continuous	+10 dBm
Junction Temperature	250 °C

Operation of this device above any of these parameters will cause permanent damage.

### S-PARAMETER REFERENCE PLANES

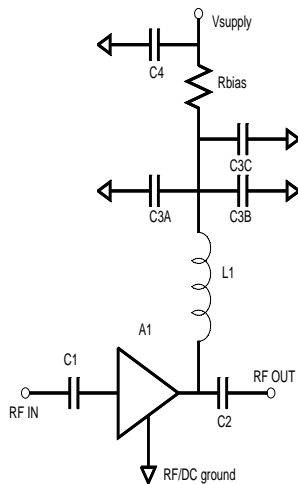
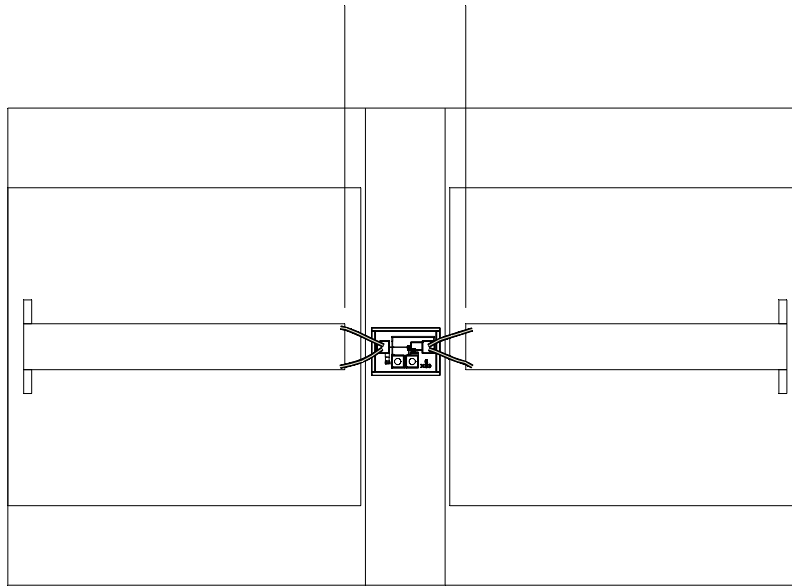

Application Schematic

#### Parts List: ( $V_{supply} = 6.00V_{dc}$ )

Rbias	22 Ohms	0603 size
C1, C2	10nF	0402 ATC520L103KT16T
C3A	10pF	0603
C3B	220pF	0603
C3C	0.1uF	0603
C4	4.7uF	1210
L1	8uH	Coilcraft BCS-802JLC

Note that Rbias is required for DC current stability with temperature.

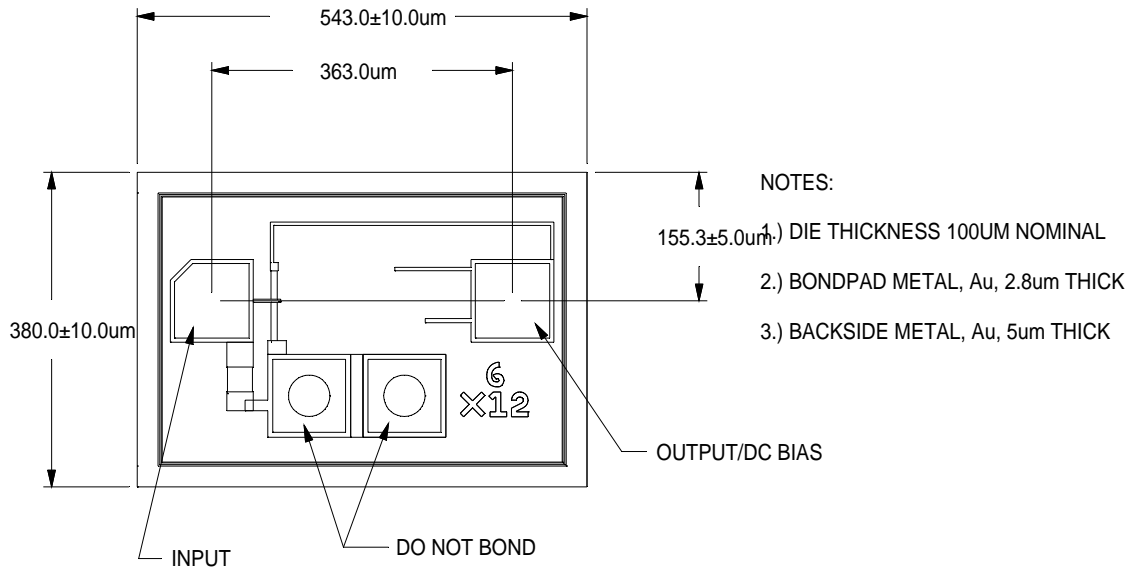

## DIE OUTLINE

GRASEN Technology, LLC reserves the right to make changes to the products listed in the data sheet at any time without notice. Consult with GRASEN or an authorized sales representative to verify the information in this data sheet before using this product. GRASEN does not assume liability for the usage of this product described herein. GRASEN does not convey a license under any patent rights, copyrights, trademark rights or any intellectual rights of GRASEN or third parties.